



AMERICAN LAFRANCE

CENTURY 2000SM

Stainless More than skin deep

CUSTOM PUMPER

Only a Pumper Truck Could Be This Good



Fights off corrosion, with body, pump enclosure and cab (except roof panel and beltline) of 304L stainless steel. Even substructure and fasteners. You get years of added service while it simplifies maintenance.



Makes repair work a snap. Modular design means pump and enclosure, water tank, cab components—even body compartments can be individually replaced. Your Century 2000 will spend more time fighting fires and less money in the shop.



Century 2000's 350-hp engine and electronic automatic transmission* give smooth power for normal driving, and surging acceleration when you need it.

*other options available



Full instrumentation and easy-to-reach controls respond quickly in heavy traffic. 28% more window area gives added visibility for maneuvering.



The American

This Easy To Keep Good an Investment

A new custom fire pumper is on the scene, with features to make it the best investment around in firefighters' apparatus.

Features like stainless steel in rust-prone areas. To stand up to the punishment of water and chemicals you see every day.

Features like modular assembly. Damaged components can be changed out in a hurry, getting your vehicle back on line while saving you the costs of extensive repairs.

Features like a powerful drive train that breezes effortlessly through typical driving rigors. And improved electronics and brakes, heavy-duty axles, high-tech operator's compartment and big American LaFrance 1500-gpm TwinFlow pump that makes short work of many calls.

All these features backed by seven nationwide service centers, and financing available through Figgie Acceptance Corp.

If you need a state-of-the-art vehicle built to add years of firefighting service, check the new Century 2000. Call today. 703/326-1121



AMERICAN LAFRANCE

CENTURY 2000™
CUSTOM PUMPER



American LaFrance is here to stay!

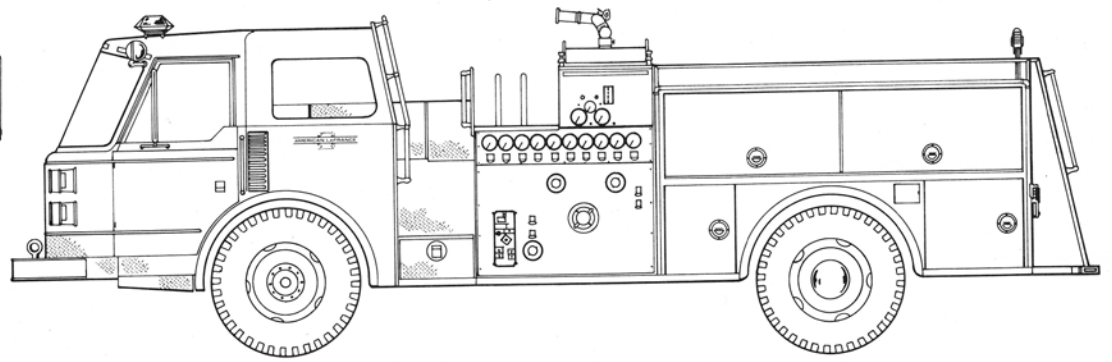
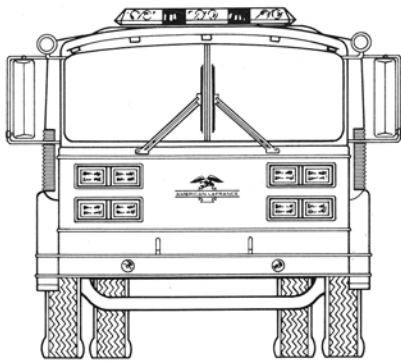

American LaFrance is back, with a new custom pumper built to fight fires years after other trucks give out.

What makes Century 2000 special?

STRENGTH AND LONG LIFE—The entire Century 2000 cab, body and pump enclosure are 304L low-carbon stainless steel, except for the beltline and roof panel. Sheet metal sub-structure and fasteners are also of stainless steel. In all those areas, you have the advantages of resistance to corrosion and metal fatigue, plus elimination of problems caused by contact of dissimilar metals.

FAST, LOW-COST REPAIRS—Modular, stainless steel compartments are built into Century 2000 bodies. In case of damage, individual units can be changed out quickly and economically.

HIGH-OUTPUT PUMPING—Inside Century 2000's brushed stainless steel pump enclosure operates an American LaFrance 1500 GPM TwinFlow pump.

The control panel, with Apollo 3422 monitor, in-line push/pull controls and full instrumentation, is quick to operate and easy-to-read.*

Standard equipment includes hose reel, Akron foam pumper system and two crosslay compartments with aluminum cover.*

The water tank of fiberglass construction will not corrode.

EFFICIENT OPERATION, HANDSOME APPEARANCE

—Century 2000's sleek, rounded cab seats 5 passengers. 28% more glass gives much greater visibility for safe maneuvering in tight quarters.

Plenty of storage space is available with four roomy compartments on each side, high side compartments on the left and one upper/one lower compartment behind the water tank.

HIGH-PERFORMANCE POWER TRAIN—The 350-hp Detroit Diesel V-6 Turbo engine drives Century 2000's electronically-controlled Allison automatic transmission and Rockwell R170 axle.* The exclusive chassis design includes all-bolted cross members.

You get added durability with heavy-duty axles, plus state-of-the-art brakes and electronics.

FAST, NATIONWIDE SERVICE—With the new Century 2000, you save time and money on equipment maintenance.

American LaFrance operates 7 service centers across the U.S. Each carries a large stock of service parts to give you faster turnaround. In fact, American LaFrance will have any major Century 2000 component, including modular compartments, water tanks, etc., within 30 days of your order!

*other options available

A custom pumper this new and this good **has** to come from American LaFrance. Can you afford to settle for less? Call your service center representative or factory today.

703/326-1121

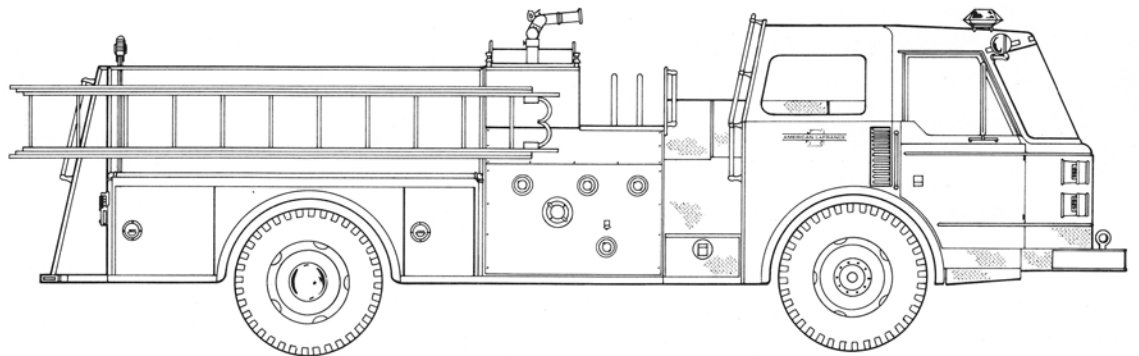
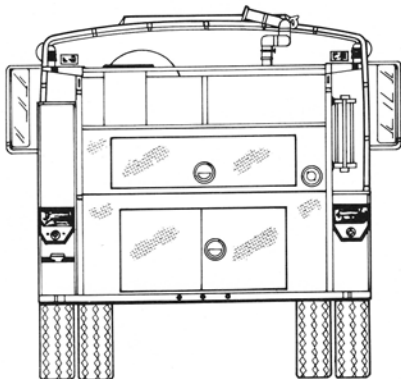

KERSEY AMERICAN LaFRANCE

A FIGGIE INTERNATIONAL COMPANY

600 Mountain Lane, Bluefield, VA 24605

©1986 Kersey American LaFrance